

# Altivar 31C

Installation manual

Wall-fixing variable speed drives  
for asynchronous motors



Drive references	2
Mounting	3
Wiring	5

**NOTE: Please also refer to the Programming Manual.**

When the drive is powered up, the power components and some of the control components are connected to the line supply. It is extremely dangerous to touch them. *The drive cover must be kept closed.*

In general, the drive power supply must be disconnected before any operation on either the electrical or mechanical parts of the installation or *machine*. After the ALTIVAR has been switched off and the display has disappeared completely, *wait for 10 minutes before working on the equipment*. This is the time required for the capacitors to discharge.

The motor can be stopped during operation by inhibiting start commands or the speed reference while the drive remains powered up. If personnel safety requires prevention of sudden restarts, this electronic locking system is not sufficient: *fit a cut-off on the power circuit..*

The drive is fitted with safety devices which, in the event of a fault, can shut down the drive and consequently the motor. The motor itself may be stopped by a mechanical blockage. Finally, voltage variations, especially line supply failures, can also cause shutdowns.

If the cause of the shutdown disappears, there is a risk of restarting which may endanger certain machines or installations, especially those which must conform to safety regulations.

*In this case the user must take precautions against the possibility of restarts, in particular by using a low speed detector to cut off power to the drive if the motor performs an unprogrammed shutdown.*

The drive must be installed and set up in accordance with both international and national standards. Bringing the device into conformity is the responsibility of the systems integrator who must observe the EMC directive among others within the European Union.

The specifications contained in this document must be applied in order to comply with the essential requirements of the EMC directive.

The Altivar 31 must be considered as a component: it is neither a machine nor a device ready for use in accordance with European directives (machinery directive and electromagnetic compatibility directive). It is the responsibility of the end user to ensure that the machine meets these standards.

The drive must not be used as a safety device for machines posing a potential risk of material damage or personal injury (lifting equipment, for example). In such applications, overspeed checks and checks to ensure that the trajectory remains under constant control must be made by separate devices which are independent of the drive.

The products and equipment described in this document may be changed or modified at any time, either from a technical point of view or in the way they are operated. Their description can in no way be considered contractual.

## Drive references

### Single phase supply voltage: 200...240 V 50/60 Hz

3-phase motor 200...240 V

Motor Power indicated on plate (1)	Line supply (input)		Max. prospective line lsc	Apparent power	Max. inrush current (3)	Drive (output)			Altivar 31 Reference
	at 200 V	at 240 V				Nominal current In (1)	Max. transient current (1) (4)	Power dissipated at nominal load	
kW/HP	A	A	kA	kVA	A	A	A	W	
0.18 / 0.25	3.0	2.5	1	0.6	10	1.5	2.3	24	<b>ATV31C018M2</b>
0.37 / 0.5	5.3	4.4	1	1.0	10	3.3	5.0	41	<b>ATV31C037M2</b>
0.55 / 0.75	6.8	5.8	1	1.4	10	3.7	5.6	46	<b>ATV31C055M2</b>
0.75 / 1	8.9	7.5	1	1.8	10	4.8/4.2 (5)	7.2	60	<b>ATV31C075M2</b>
1.1 / 1.5	12.1	10.2	1	2.4	19	6.9	10.4	74	<b>ATV31CU11M2</b>
1.5 / 2	15.8	13.3	1	3.2	19	8.0	12.0	90	<b>ATV31CU15M2</b>
2.2 / 3	21.9	18.4	1	4.4	19	11.0	16.5	123	<b>ATV31CU22M2</b>

### 3-phase supply voltage: 380...500 V 50/60 Hz

3-phase motor 380...500 V

Motor Power indicated on plate (1)	Line supply (input)		Max. prospective line lsc	Apparent power	Max. inrush current (3)	Drive (output)			Altivar 31 Reference
	at 380 V	at 500 V				Nominal current In (1)	Max. transient current (1) (4)	Power dissipated at nominal load	
kW/HP	A	A	kA	kVA	A	A	A	W	
0.37 / 0.5	2.2	1.7	5	1.5	10	1.5	2.3	32	<b>ATV31C037N4</b>
0.55 / 0.75	2.8	2.2	5	1.8	10	1.9	2.9	37	<b>ATV31C055N4</b>
0.75 / 1	3.6	2.7	5	2.4	10	2.3	3.5	41	<b>ATV31C075N4</b>
1.1 / 1.5	4.9	3.7	5	3.2	10	3.0	4.5	48	<b>ATV31CU11N4</b>
1.5 / 2	6.4	4.8	5	4.2	10	4.1	6.2	61	<b>ATV31CU15N4</b>
2.2 / 3	8.9	6.7	5	5.9	10	5.5	8.3	79	<b>ATV31CU22N4</b>
3 / 3	10.9	8.3	5	7.1	10	7.1	10.7	125	<b>ATV31CU30N4</b>
4 / 5	13.9	10.6	5	9.2	10	9.5	14.3	150	<b>ATV31CU40N4</b>

(1) These power ratings and currents are for a maximum ambient temperature of 40°C and a switching frequency of 4 kHz in continuous operation. The switching frequency is adjustable from 2 to 16 kHz.

Above 4 kHz, the drive will reduce the switching frequency in the event of excessive temperature rise. The temperature rise is controlled by a PTC probe in the power module. Nonetheless, the nominal drive current should be derated if operation above 4 kHz needs to be continuous.

Derating curves are shown on page 4 as a function of switching frequency and ambient temperature.

(2) Current on a line supply with the "Max. prospective line lsc" indicated.

(3) Peak current on power-up, for the max. voltage (240 V + 10%, 500 V + 10%).

(4) For 60 seconds.

(5) 4.8 A at 200 V/4.6 A at 208 V/4.2 A at 230 V and 240 V.

# Mounting

## Dimensions and weights

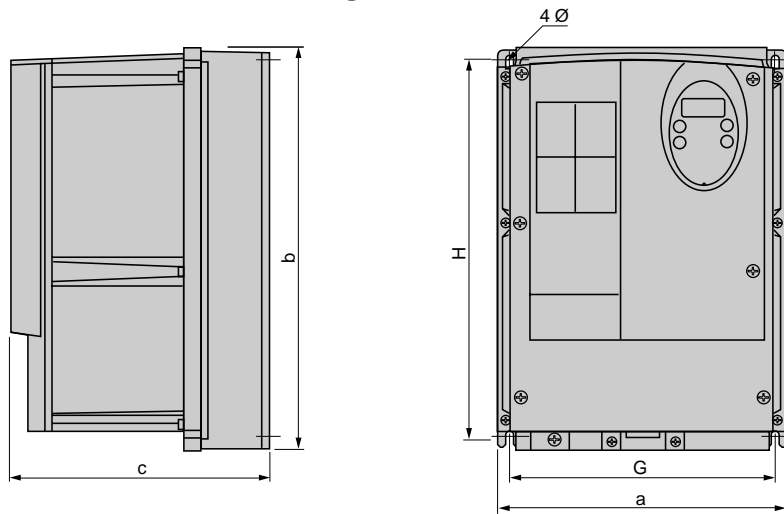

ATV 31C		a mm	b mm	c mm	G mm	H mm	Ø mm	For screws	Weight kg
018M2, 037M2, 055M2, 075M2	Size 1	210	240	163	192	218	5.5	M5	6.300
U11M2, U15M2, 037N4, 055N4, 075N4, U11N4, U15N4	Size 2	215	297	192	197	277	5.5	M5	8.800
U22M2, U22N4, U30N4, U40N4	Size 3	230	340	222	212	318	5.5	M5	10.700

# Mounting

## Mounting and temperature conditions

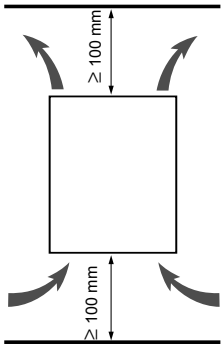

Install the unit vertically, at  $\pm 10^\circ$ .

Do not place it close to heating elements.

Leave sufficient free space to ensure that the air required for cooling purposes can circulate from the bottom to the top of the unit.

Minimum and maximum ambient air temperatures permissible during operation:

$-10^\circ\text{C}$  to  $+40^\circ\text{C}$

## Derating curves for the drive current $I_n$ as a function of the temperature and switching frequency

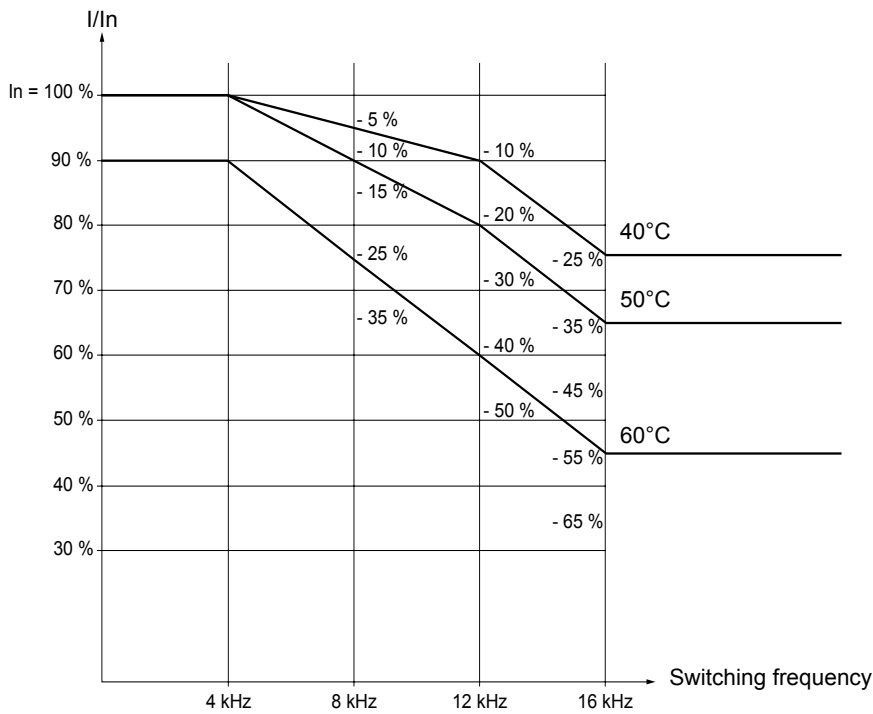

For intermediate temperatures (e.g.  $55^\circ\text{C}$ ), interpolate between 2 curves.

# Wiring

## Access to terminals

To access the terminals, open the cover as shown in the example below.

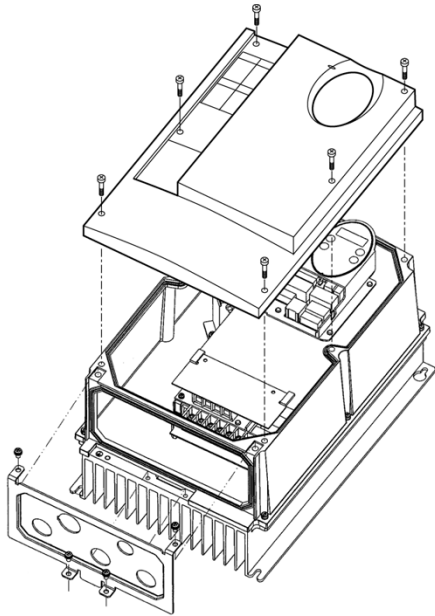

Example: ATV31CU22M2

## Power terminals



Connect the power terminals before connecting the control terminals.

### Power terminal characteristics

Altivar ATV 31C	Maximum connection capacity		Tightening torque in Nm
	AWG	mm <sup>2</sup>	
018M2, 037M2, 055M2, 075M2	AWG 14	2.5	0.8
U11M2, U15M2, U22M2, 037N4, 055N4, 075N4, U11N4, U15N4, U22N4, U30N4, U40N4	AWG 10	5	1.2

### Power terminal functions

Terminal	Function	For Altivar ATV 31
⏚	Ground terminal	All ratings
R/L1 S/L2	Power supply	ATV31C●●●●M2
R/L1 S/L2 T/L3		ATV31C●●●●N4
PO	DC bus + polarity	All ratings
PA/+	Output to braking resistor (+ polarity)	All ratings
PB	Output to braking resistor	All ratings
PC/-	DC bus - polarity	All ratings
U/T1 V/T2 W/T3	Outputs to the motor	All ratings



Never remove the commoning link between PO and PA/+.

# Wiring

## Arrangement of the power terminals

ATV 31C018M2, 037M2, 055M2, 075M2

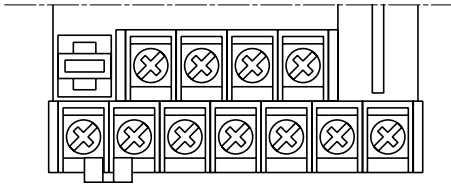

		R/L1	S/L2				
P0	PA/+	PB	PC/-	U/T1	V/T2	W/T3	

ATV 31CU11M2, U15M2, U22M2

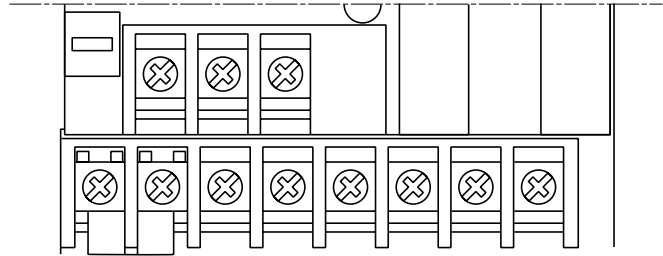

	R/L1	S/L2							
P0	PA/+	PB	PC/-	U/T1	V/T2	W/T3			

ATV 31C037N4, 055N4, 075N4, U11N4, U15N4, U22N4,  
U30N4, U40N4

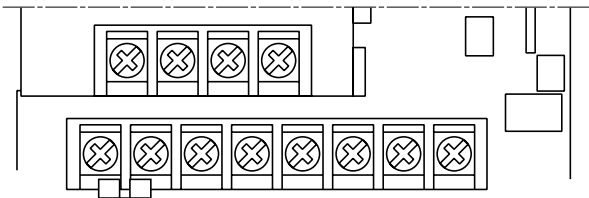

	R/L1	S/L2	T/L3						
P0	PA/+	PB	PC/-	U/T1	V/T2	W/T3			

# Wiring

## Control terminals

### Arrangement of the control terminals

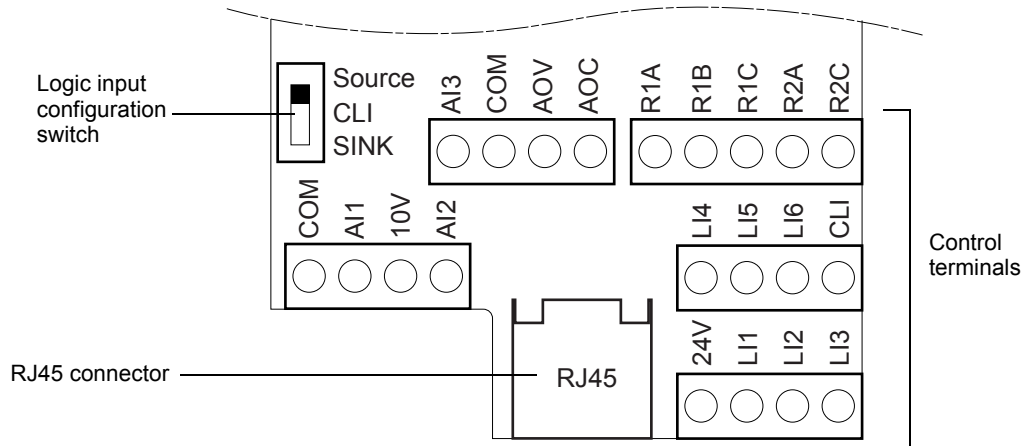

- Maximum connection capacity: 2.5 mm<sup>2</sup> - AWG 14
- Max. tightening torque: 0.6 Nm

# Wiring

## Characteristics and functions of the control terminals

Terminal	Function	Electrical characteristics
R1A R1B R1C	Common point C/O contact (R1C) of programmable relay R1	<ul style="list-style-type: none"> <li>• Min. switching capacity: 10 mA for 5 V <math>\text{---}</math></li> <li>• Max. switching capacity on resistive load (<math>\cos \varphi = 1</math> and <math>L/R = 0</math> ms): 5 A for 250 V <math>\sim</math> and 30 V <math>\text{---}</math></li> </ul>
R2A R2C	N/O contact of programmable relay R2	<ul style="list-style-type: none"> <li>• Max. switching capacity on inductive load (<math>\cos \varphi = 0.4</math> and <math>L/R = 7</math> ms): 1.5 A for 250 V <math>\sim</math> and 30 V <math>\text{---}</math></li> <li>• Sampling time 8 ms</li> <li>• Service life: 100,000 operations at max. switching power 1,000,000 operations at min. switching power</li> </ul>

COM	Analog I/O common	0 V
AI1	Analog voltage input	Analog input 0 + 10 V (max. safe voltage 30 V) <ul style="list-style-type: none"> <li>• Impedance 30 k<math>\Omega</math></li> <li>• Resolution 0.01 V, 10-bit converter</li> <li>• Precision <math>\pm 4.3\%</math>, linearity <math>\pm 0.2\%</math>, of max. value</li> <li>• Sampling time 8 ms</li> <li>• Operation with shielded cable 100 m max.</li> </ul>
10 V	Power supply for reference potentiometer 1 to 10 k $\Omega$	+ 10 V (- 0, + 8%), 10 mA max, protected against short-circuits and overloads
AI2	Analog voltage input	Bipolar analog input 0 $\pm$ 10 V (max. safe voltage $\pm$ 30 V) <b>The + or - polarity of the voltage on AI2 affects the direction of the reference and therefore the direction of operation.</b> <ul style="list-style-type: none"> <li>• Impedance 30 k<math>\Omega</math></li> <li>• Resolution 0.01 V, 10-bit + sign converter</li> <li>• Precision <math>\pm 4.3\%</math>, linearity <math>\pm 0.2\%</math>, of max. value</li> <li>• Sampling time 8 ms</li> <li>• Operation with shielded cable 100 m max.</li> </ul>

AI3	Analog current input	Analog input X - Y mA. X and Y can be programmed from 0 to 20 mA <ul style="list-style-type: none"> <li>• Impedance 250 <math>\Omega</math></li> <li>• Resolution 0.02 mA, 10-bit converter</li> <li>• Precision <math>\pm 4.3\%</math>, linearity <math>\pm 0.2\%</math>, of max. value</li> <li>• Sampling time 8 ms</li> </ul>
COM	Analog I/O common	0 V
AOV or AOC	Analog voltage output AOV or Analog current output AOC or Logic voltage output AOC AOV or AOC can be assigned (either, but not both)	Analog output 0 to 10 V, min. load impedance 470 $\Omega$ or Analog output X - Y mA. X and Y can be programmed from 0 to 20 mA, max. load impedance 800 $\Omega$ <ul style="list-style-type: none"> <li>• Resolution 8 bits (1)</li> <li>• Precision <math>\pm 1\%</math> (1)</li> <li>• Linearity <math>\pm 0.2\%</math> (1)</li> <li>• Sampling time 8 ms</li> </ul> This analog output can be configured as a 24 V logic output on AOC, min. load impedance 1.2 k $\Omega$ . (1) Characteristics of digital/analog converter.

24V	Logic input power supply	+ 24 V protected against short-circuits and overloads, min. 19 V, max. 30 V Max. customer current available 100 mA
LI1 LI2 LI3	Logic inputs	Programmable logic inputs <ul style="list-style-type: none"> <li>• + 24 V power supply (max. 30 V)</li> <li>• Impedance 3.5 k<math>\Omega</math></li> <li>• State 0 if <math>&lt; 5</math> V, state 1 if <math>&gt; 11</math> V (voltage difference between LI- and CLI)</li> <li>• Sampling time 4 ms</li> </ul>

LI4 LI5 LI6	Logic inputs	Programmable logic inputs <ul style="list-style-type: none"> <li>• + 24 V power supply (max. 30 V)</li> <li>• Impedance 3.5 k<math>\Omega</math></li> <li>• State 0 if <math>&lt; 5</math> V, state 1 if <math>&gt; 11</math> V (voltage difference between LI- and CLI)</li> <li>• Sampling time 4 ms</li> </ul>
CLI	Logic input common	See page 12.

# Wiring

## Wiring diagram for factory settings

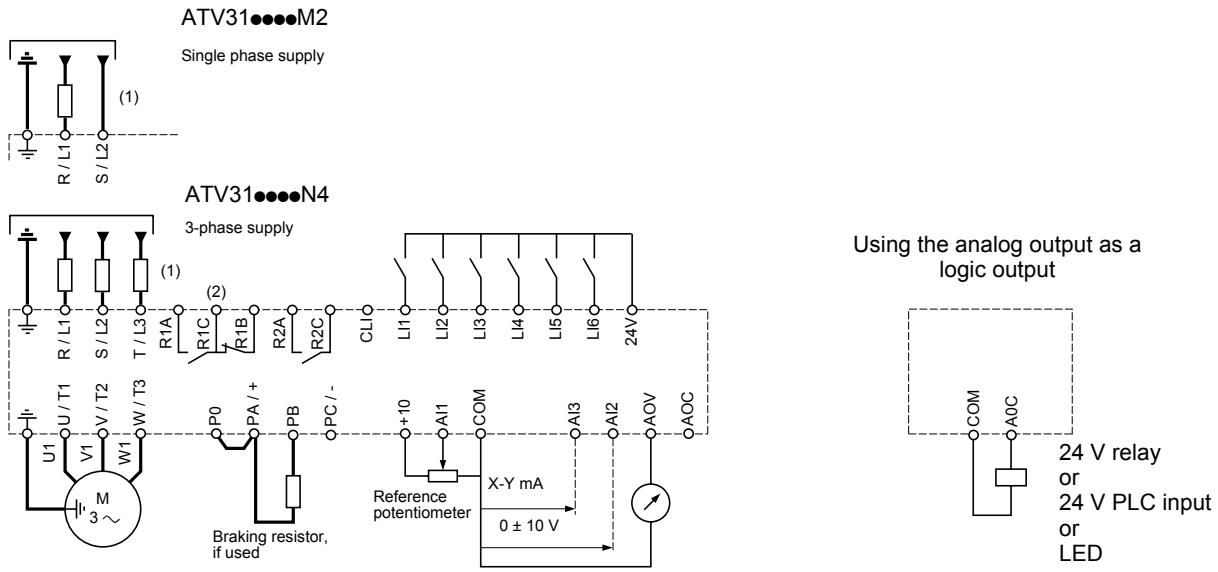

- (1) Line choke, if used (single phase or 3-phase)
- (2) Fault relay contacts, for remote indication of the drive status

**Note:** Fit interference suppressors to all inductive circuits near the drive or coupled to the same circuit (relays, contactors, solenoid valves, etc).

**Choice of associated components:**  
Please refer to the catalogue.

## Logic input switch

This switch assigns the logic input common link to 0 V, 24 V or "floating":

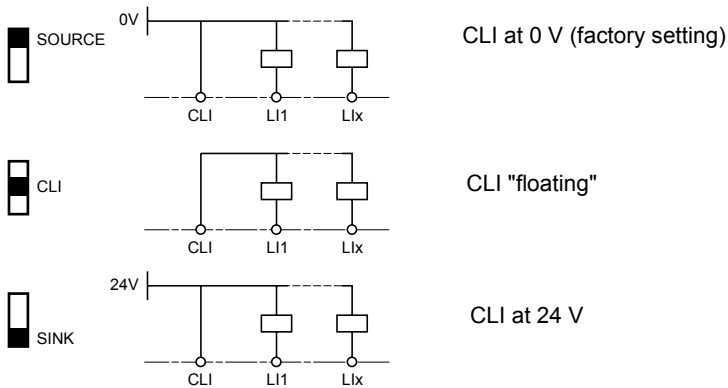

# Wiring

## Examples of recommended circuit diagrams

### Using volt-free contacts

- Switch in "Source" position

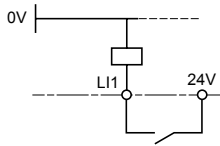

- Switch in "SINK" position

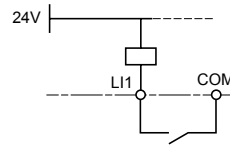

### Using PLC transistor outputs

- Switch in CLI position

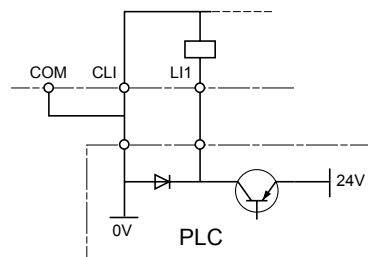

- Switch in CLI position

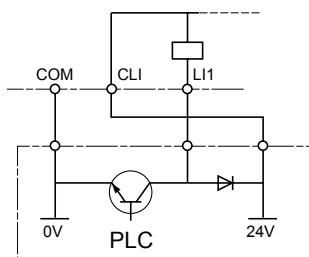

## Wiring recommendations

### Power

The drive must be earthed to conform with the regulations concerning high leakage currents (over 3.5 mA).

When upstream protection by means of a "residual current device" is required by the installation standards, a type A device should be used for single phase drives and type B for 3-phase drives. Choose a suitable model incorporating:

- HF current filtering
- a time delay which prevents tripping caused by the load from stray capacitance on power-up. The time delay is not possible for 30 mA devices. In this case, choose devices with immunity against accidental tripping, for example RCDs with reinforced immunity from the s.i range (Merlin Gerin brand).

If the installation includes several drives, provide one "residual current device" per drive.

Keep the power cables separate from circuits in the installation with low-level signals (detectors, PLCs, measuring apparatus, video, telephone).

If you are using cables > 50 m between the drive and the motor, add output filters (please refer to the catalogue).

### Control

Keep the control circuits away from the power cables. For control and speed reference circuits, we recommend using shielded twisted cables with a pitch of between 25 and 50 mm, connecting the shielding to ground at each end.

# Wiring

---

## Operation on an IT system

IT system: Isolated or impedance earthed neutral.

Use a permanent insulation monitor compatible with non-linear loads: a Merlin Gerin type XM200, for example.

ATV 31C●●● drives feature built-in RFI filters. These filters can be isolated from ground for operation on an IT system as follows:

**ATV31C018M2 to U22M2 and ATV31C037N4 to U40N4:**

Pull out the jumper on the left of the ground terminal as illustrated below.

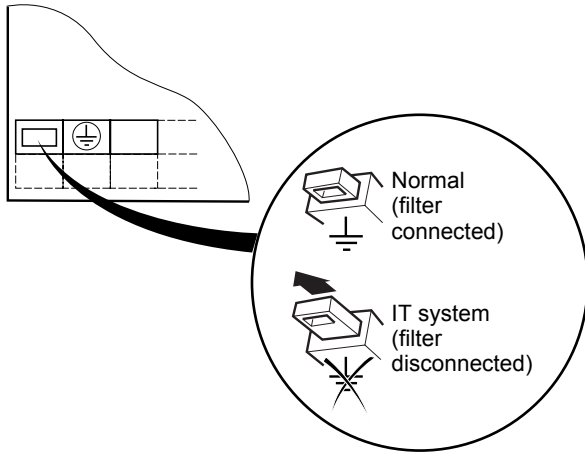

# Wiring

## Electromagnetic compatibility

### Principle

- Grounds between the drive, the motor and the cable shielding must have "high frequency" equipotentiality.
- Use of shielded cables with shielding connected to ground throughout 360° at both ends for the motor cables, braking resistor (if used) and control-signalling wiring. Conduit or metal ducting can be used for part of the shielding length provided that there is no break in continuity.
- Ensure maximum separation between the power supply cable (line supply) and the motor cable.

### Installation diagram (example: ATV31CU22M2)

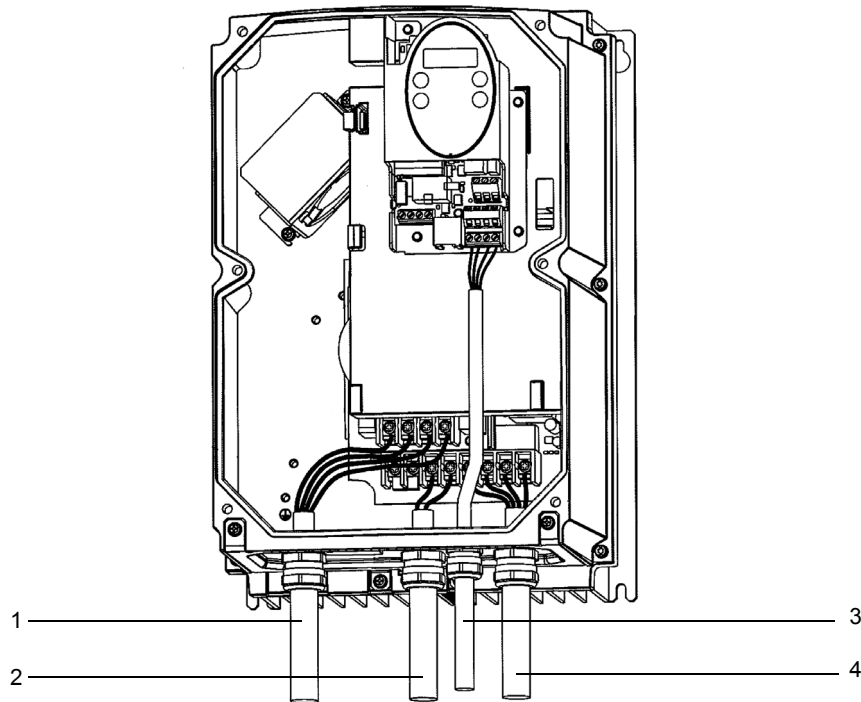

1 Non-shielded power supply cable: use a standard cable gland (not supplied).

2 Shielded cable for connecting the braking resistor, if used: use a metal EMC cable gland (not supplied).

3 Shielded cable for connecting the control/signalling wiring: use a metal EMC cable gland (not supplied).  
For applications requiring several conductors, use cables with a small cross-section ( $0.5 \text{ mm}^2$ ).

4 Shielded cable for connecting the motor: use a metal EMC cable gland (not supplied).  
For 0.18 to 1.5 kW drives, if the switching frequency is higher than 12 kHz, use cables with low linear capacitance: max. 130 pF (picoFarads) per meter.

## Assembling and connecting a shielded cable with metal cable gland:

- Prepare the shielded cable by stripping both ends ready for connection.
- Loosen the cover of the cable gland.
- Fit the shielded cable in the cable gland ensuring it is fully in contact (throughout 360°).
- Fold back the shielding and clamp it between the ring and the body of the cable gland, and tighten the cover.

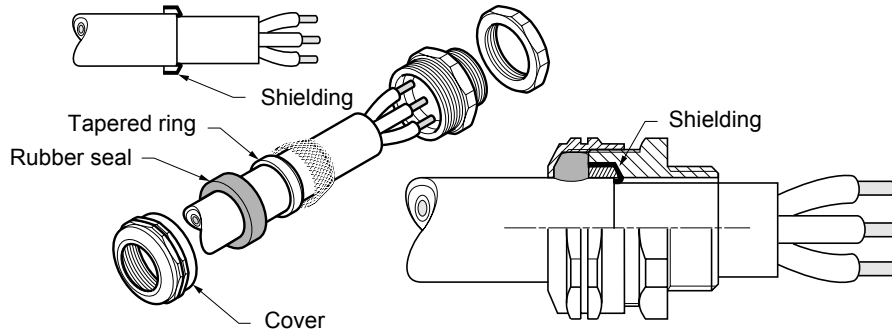

## Cable gland diameters to be used

ATV31C	Hole diameters (PG... cable gland) for cable:			
	Power supply	Motor	Control/signalling	Braking resistor (if used)
018M2, 037M2, 055M2, 075M2	19 mm (PG11)	21 mm (PG13.5)	19 mm (PG11)	19 mm (PG11)
U11M2, U15M2, 037N4, 055N4, 075N4, U11N4, U15N4	23 mm (PG16)	23 mm (PG16)	19 mm (PG11)	23 mm (PG16)
U22M2, U22N4, U30N4, U40N4	23 mm (PG16)	23 mm (PG16)	19 mm (PG11)	23 mm (PG16)

## Customizing the wall-fixing drive

This range allows full customization of the human-machine interface part of the enclosure.

The ATV 31C has removable blanking plates where the following components can be added:

- Vario switch disconnecter or GV2 circuit-breaker
- 3 buttons and/or LEDs with plastic flange (∅ 22) and 1 speed reference potentiometer

Example:

- 3-pole Vario switch disconnecter (V●● + KC● 1●Z)
- Selector switch with 3 fixed positions XB5 D33
- LED XB5 AV●●
- 2.2 kΩ potentiometer

These references can be found in our catalogues "Power control and protection components" and "Human-Machine Interface Components".

All components must be ordered separately and wired by the customer.

### Mounting example for a Vario switch

1) Remove the blanking plate

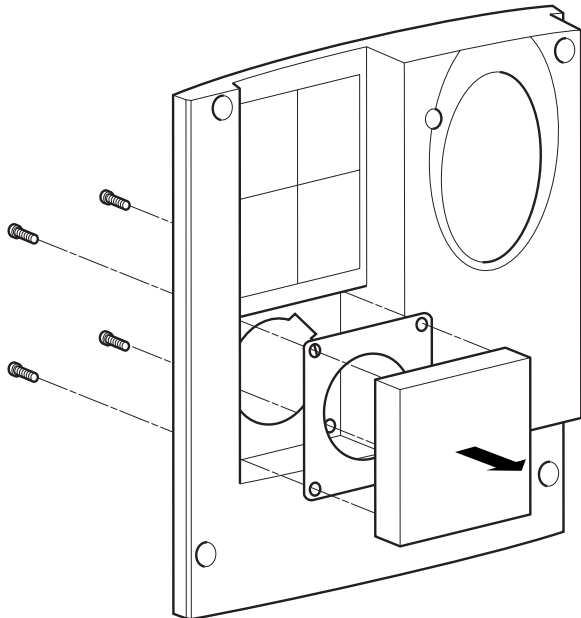

2) Mount the Vario switch

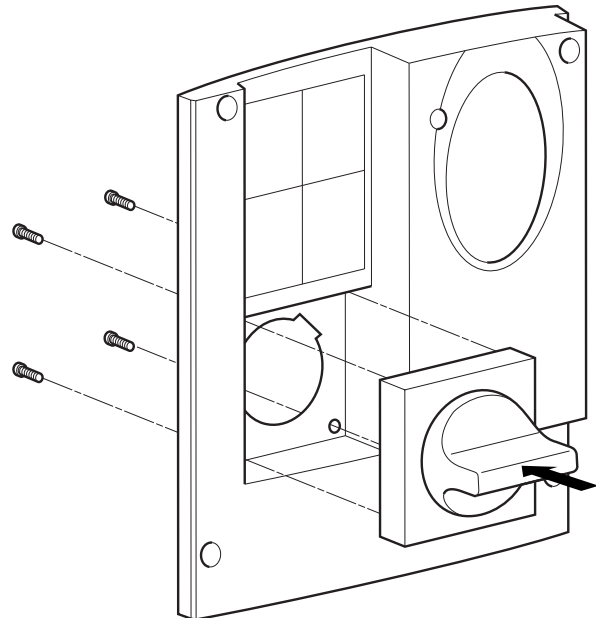

# Wiring

## Using the RJ45 socket

Using the dust and damp proof (IP55) RJ45 cable VW3A01500 and cable VW3A01501

VW3A01500

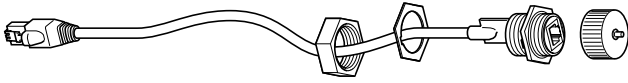

1)

VW3A01501



2)

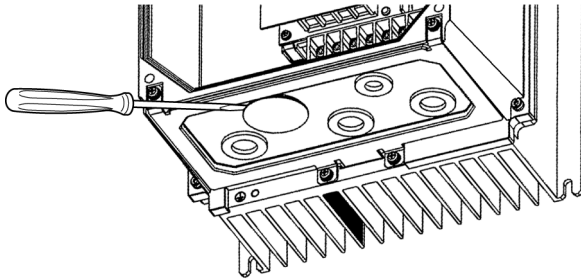

3)

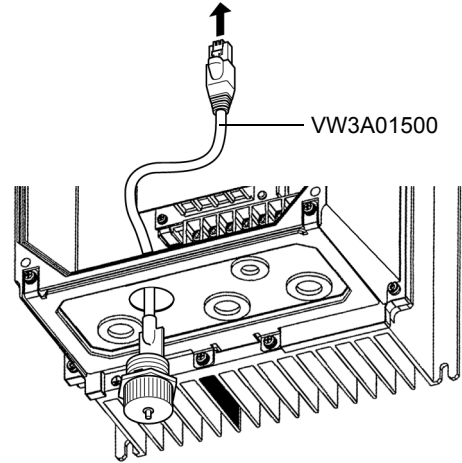

4)

